

MIPS Series MEDICAL ISOLATION POWER SYSTEMS

IT Systems are distribution systems which are preferred less compared to Grounded Systems at Industrial Institutions however mandatory to use at Group-2 rooms in hospitals due to the electricity safety that is maintained in compliance to IEC 60364-7-710 Standard.

The main difference that discriminates IT systems from Grounded Systems (TN or TT) is the non-presence of the Institution Grounding. This is obtained by isolation transformer and each load that is connected to this distribution system has its own individual grounding. These systems are mainly used in the supply of the hospital critical rooms like surgery, intensive care, premature childbirth, angiography examination rooms.

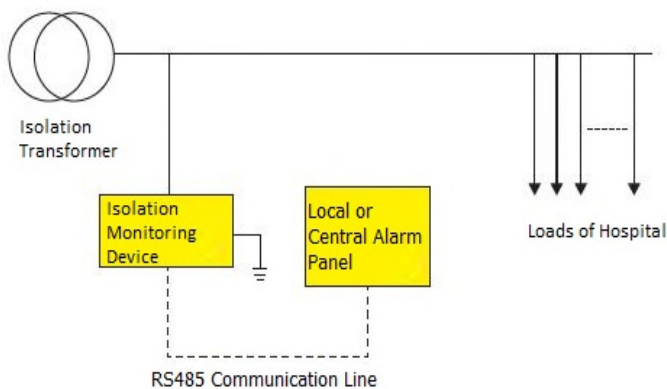

MIPS Devices;

Complete MIPS devices are as follows;

Standard:

- Distribution Panel
- Circuit Breakers for output distribution
- Isolation Transformer (comply with IEC 61558-2-15)
- Isolation Monitoring Device (IZL IMM)

Options:

- Isolation Error Detection System (IZL CM6X)
- Local & Central Alarm Panel (IZL LAP & IZL LAP/M)
- Static Transfer Switch or Contactor for Change over

Key Features

- Providing isolation for critical loads especially in emergency & operating rooms in hospitals
- Maintaining the security of doctor and patient
- Preventing the energy interruption
- Displaying the status info of Utility
- 50-500kΩ isolation resistor
- 5-50A Load Current
- Menu adjustment on LCD screen
- Data transmission through RS232/485
- Transfer less than 5ms (with STS)
- Determination of fault location (with IZL CM6X)
- Remote monitoring (with IZL LAP)
- Central Monitoring System (with IZL-LAP/M)
- Customizing the Panel according to project

Benefits of the Isolation System;

- * In the event of first isolation failure, energy blackout does not happen. The security equipment controls the system continuously therefore the energy blackout is prevented.
- * The Medical Devices continue their normal operations.
- * Fault Currents are reduced to non-critical levels which means the leakage current that is present within the room is reduced from mA levels to μ A levels.
- * A possible inconvenience in the surgery room is prevented where energy is reserved, and blackout does not happen.

